

1) Verankerung der hinteren Verstärkung mit Verankerungsbügeln an den letzten 3 Pfosten (siehe Detail X)

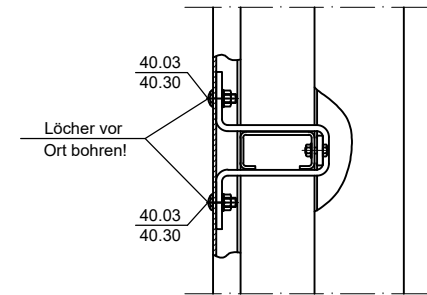
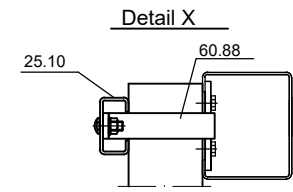
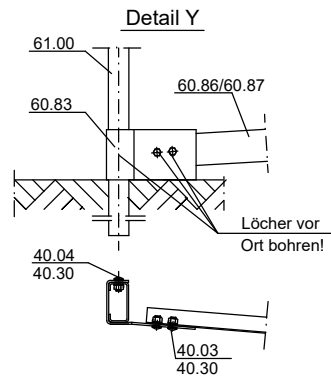
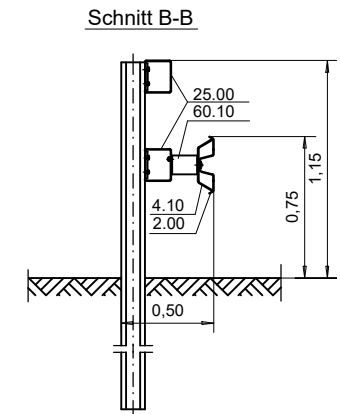
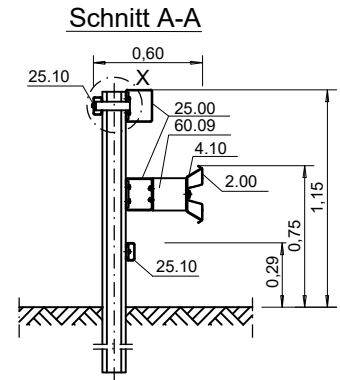
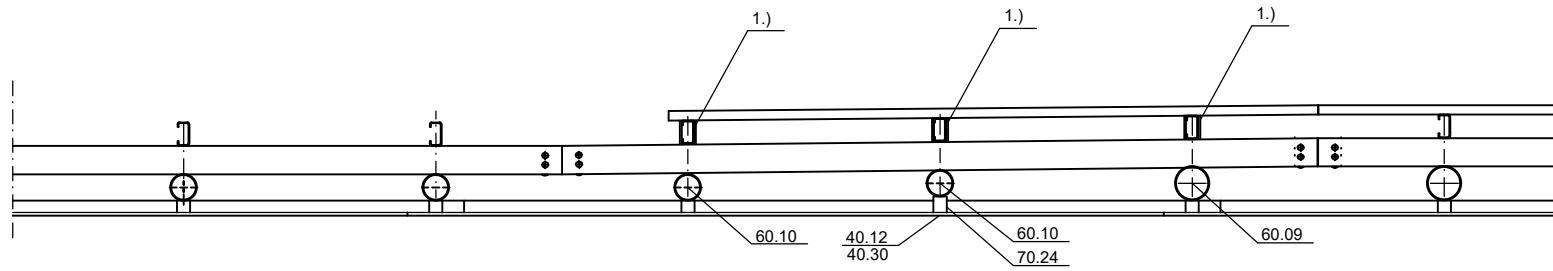

Die Konstruktion ist patentrechtlich geschützt.

Verschraubung siehe Zeichnung Nr. B1.1-202 und B1.1-203

Profil A sinngemäß ausführen.

Zchg. Nr. S3.1-316	Übergang SUPER-RAIL Plus auf SUPER-RAIL	-----
Stand: Dez. 2020		
Gütegemeinschaft Stahlschutzplatten e.V.	-----	-----

